

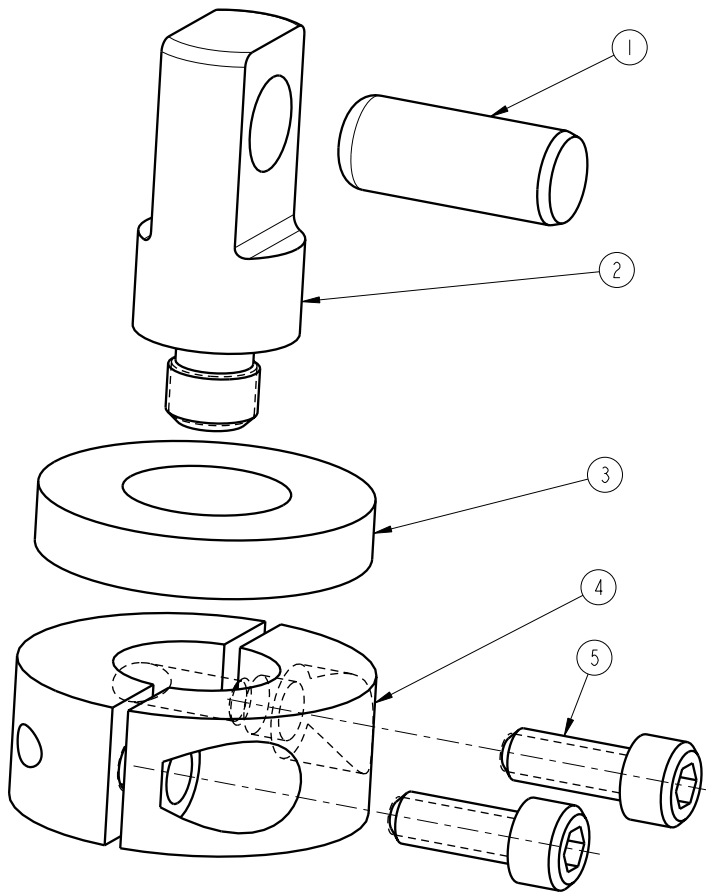

VEKTEK METRIC
ASSY, ATCH, ROCKER ARM, SC

No.	QTY	DESCRIPTION	44-5205-09 2 kN	44-5209-09 4.9 kN	44-5213-09 11.6 kN
1	1	PIN, DOWEL	90199909	90199910	90199911
2	1	STUD, PIVOT	47570500	47570900	47571300
3	1	WASHER, ELASTOMER	21430005	21430006	21430007
4	1	COLLAR, CLAMP	47901906	47901907	47901908
N/A	N/A	CAPSCREW TORQUE	4,6 N-m / 41 in-lb	9,5 N-m / 85 in-lb	16 N-m / 140 in-lb



PARTS LIST	 VEKTEK, INC. 1334 E. SIXTH AVE. P.O. BOX 625 EMPORIA, KS. 66801 U.S.A.
	ASSEMBLIES AFFECTED 44-5205-09, 44-5209-09 44-5213-09
PARTS LIST, ASSY, ATCH, ROCKER ARM, SC	
SIZE A	MPLV9101
REV A	REV A

A	2552	RELEASE	JDW	07/15/13
REV	IN ACCORDANCE WITH ECN	EFFECTIVE DATE	REVISED BY	DATE
DRW BY:	JDW	DRAWING STATUS: Released PRODUCTION APPROVED FOR RELEASED STATUS ONLY		
DATE:	07/15/13			

SHEET 1 OF 1